

What's Inside:

- 1 Key Benefits
- 2 Increase Intelligence, Not Operating Costs
- 2 Simplify Your Network
- 2 Maximize Large-Scale Application Performance
- 2 Achieve Ultimate Reliability
- 2 The Advantages of VIPRION Technology
- 5 VIPRION Platforms
- 9 Ordering Information
- 9 Professional Services and Support
- 9 More Information



The On-Demand Application Delivery Controller

Your organization's growing infrastructure puts more pressure on the network—from rising numbers of users to data center consolidation to the deployment of more feature-rich applications. Scaling the Application Delivery Network (ADN) to meet these evolving needs means increased operational cost and complexity. The resulting strain on resources can limit your organization's ability to react quickly to developing needs.

Each VIPRION® platform is a single, powerful Application Delivery Controller (ADC) with modular performance blades you can add or remove with no disruption to your applications. Instead of adding more devices in the network and segmenting applications, you can simply add more power to your existing infrastructure as needs arise. VIPRION gives you the scalability you need to establish a solid and sustainable ADN growth strategy.

Key benefits

On-demand intelligence

Add intelligence without reconfiguring the network or the app—and without increasing operating costs.

High performance

Manage demanding apps with layer 4 and layer 7 connection management and SSL processing power.

Device consolidation

Reduce the number of servers and ADCs along with power, space, cooling, and management requirements.

Ultimate reliability

Make the ADN always available with redundancy at both the chassis and blade levels.



VIPRION 4400 Chassis



VIPRION 2400 Chassis

VIPRION blades can be added or removed without disruption. For more processing power, simply add a blade. It starts processing traffic automatically. In a VIPRION system with multiple blades, you can remove a blade and the others instantly take over the processing load.

Increase Intelligence, Not Operating Costs

As your growing infrastructure requires more processing power for layer 4 and layer 7 processing, SSL, compression, and more, you can simply add a blade to the VIPRION chassis and it will start processing traffic automatically. Whether you're using one blade or four, VIPRION remains one device with fixed management costs.

Simplify Your Network

VIPRION can help you simplify your network by offloading servers and consolidating devices, saving management costs as well as power, space, and cooling in the data center.

With VIPRION's massive performance and scalability, you can reduce the number of Application Delivery Controllers you need to deliver even the most demanding applications. By offloading computationally intense processes, VIPRION can significantly reduce the number of application servers needed. VIPRION includes:

- SSL hardware acceleration—Offloads costly SSL encryption. Accelerates key exchange and bulk encryption to provide best-in-market SSL performance.
- HTTP compression—Enables you to cost effectively offload traffic compression processing from your servers. Improves page load times and reduces bandwidth utilization.
- OneConnect™ connection pooling—Aggregates millions of TCP requests into hundreds of server-side connections. Increases server capacity and ensures requests are handled efficiently by the back-end system.

Maximize Large-Scale Application Performance

With its industry-leading layer 4, and layer 7, and SSL performance, VIPRION can manage the most demanding applications, offload the servers, and consolidate the Application Delivery Network.

Achieve Ultimate Reliability

In a VIPRION system with multiple blades, you can remove a blade without disruption. The other blades will instantly take over the processing load. You can also deploy VIPRION in an active/standby configuration to add another level of redundancy. The chassis is built with redundant power supplies and field swappable components. This multi-layered redundancy significantly reduces the possibility of downtime.

The Advantages of VIPRION Technology

With VIPRION, your organization will benefit from several patented hardware and software innovations that offer unmatched capabilities.

Using clustered multiprocessing, VIPRION creates a virtualized processing fabric to efficiently use these resources. When you add a new blade, the additional processor cores seamlessly join the system. In the unlikely event of a failure, you can remove the blade from the system without disruption.

Using clustered multi-processing, VIPRION shares resources efficiently across the entire chassis.



The VIPRION chassis has field replaceable parts and redundant power supplies, significantly reducing the possibility of downtime.

The VIPRION 4200 blade has eight processor cores, and the VIPRION 4400 chassis can support four blades.

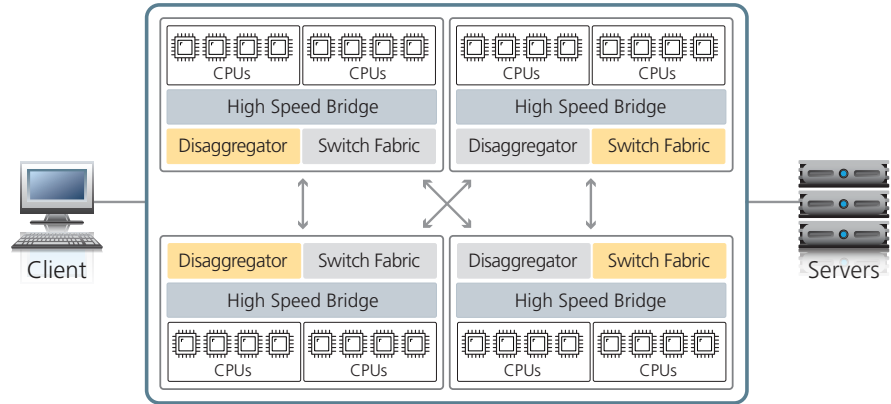

The VIPRION 2100 blade has four processor cores, and the VIPRION 2400 chassis can support four blades.

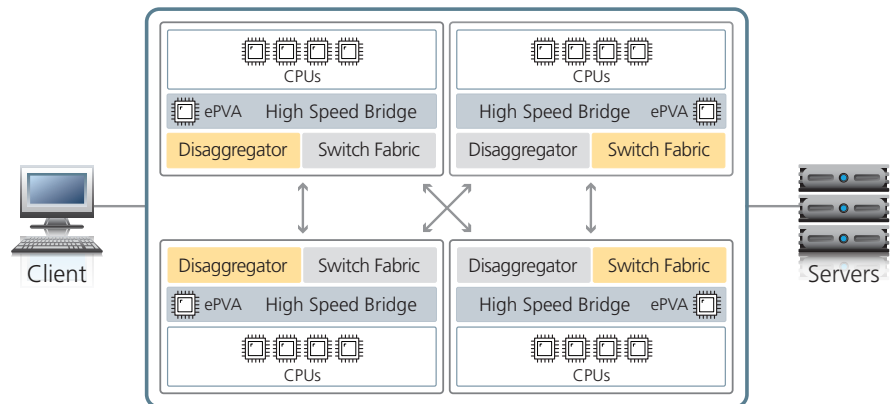

Virtualized processing fabric shares the load across blades

Using custom disaggregation ASICs and advanced software, VIPRION shares the processing load not just within a blade, but across the entire chassis.

The physical interfaces are fully meshed. Any port on any blade can be used for any application, so the system can be wired for redundancy and simplicity.

Clustered management cuts administration time

Spend less time managing your Application Delivery Network. To administrators, the VIPRION unit looks like a single Application Delivery Controller. One blade is automatically selected as the "primary" and all settings and controls are mirrored to the other blades. When a new blade is plugged in, it will install the firmware version from the primary blade, copy all of its settings, and begin processing traffic within minutes.

SuperVIP simplifies the network

Rather than requiring that a single, demanding application be segmented, VIPRION uses SuperVIP. This is a virtual IP that can span multiple blades within the VIPRION system. A demanding application will use SuperVIP to harness the processing power of all the blades in the system.

TMOS delivers performance and flexibility

At the heart of VIPRION is the F5 unique operating system called TMOS® that provides a unified system for optimal application delivery, giving you total vision, flexibility, and control across all services. TMOS empowers VIPRION to intelligently adapt to the diverse and evolving requirements of applications and networks.

VIPRION Platforms

Each VIPRION system consists of a chassis and one to four blades.



VIPRION 4400 Chassis

Physical Specifications VIPRION 4400 Chassis

Dimensions	12.2" (30.9 cm) H x 17.4" (44.2 cm) W x 21" (53.3 cm) D rack-mount chassis 7 rack units
Weight:	87 lbs. (63.0 kg) (4 power supplies, 1 fan tray, 3 blanks)
Power Supply:	Four 90 VAC to 240 VAC auto ranging 1435W maximum draw for low line input 2390W maximum draw for high line input 36VDC to 72VDC (option)
Operating Temperature:	32° to 104° F (0° to 40° C) per Telcordia GR-63-CORE 5.1.1 and 5.1.2
Relative Humidity:	10 to 90% @ 40° C per Telcordia GR-63-CORE 5.1.1 and 5.1.2
Safety Agency Approval:	UL 60950 (UL1950-3) CSA-C22.2 No. 60950-00 (bi-national standard with UL 60950) CB test certification to IEC 950 EN 60950 NEBS Certified (option)
Electromagnetic Emissions Certifications:	EN55022 1998 Class A EN55024 1998 Class A FCC Part 15B Class A VCCI Class A



VIPRION 4200 Blade



VIPRION 4100 Blade

Physical Specifications

VIPRION 4200 Blade

VIPRION 4100 Blade

Traffic Throughput:	18 Gbps L4, 18 Gbps L7, 12 Gbps max compression Included SSL TPS: 500/CPU core 4000/blade Max TPS: 50,000 Bulk crypto: 9 Gbps	10 Gbps L4, 10 Gbps L7, 4.5 Gbps max compression Included SSL TPS: 500/CPU core 2000/blade Max TPS: 50,000 Bulk crypto: 9 Gbps
Processors:	2 quad core processors	2 dual core processors
Memory:	16 GB	8 GB
Hard Drive Capacity:	160 GB hard drive 8 GB compact flash	160 GB hard drive 8 GB compact flash
Network Interfaces:	One 10/100/1000 Mbps Ethernet management port Four 10/100/1000 Mbps copper ports Eight 1000 Mbps/10 Gbps SFP+ fiber ports 2 ea. 10BASE-SR – 850nm transceivers included Note: Only optics provided by F5 are supported.	One 10/100/1000 Mbps Ethernet management port Eight 10/100/1000 Mbps copper ports Twelve 1000 Mbps BASE-X SFP fiber ports Four SFP SX transceivers (LC Connector) included Two 10 Gbps XFP ports (XFPs sold separately) Note: Only optics provided by F5 are supported.
Power Consumption:	Typical: 325W (under heavy load) Maximum: 350W	Typical: 300W (under heavy load) Maximum: 325W
Heat Output:	Typical: 1100 BTU/hour Maximum: 1200 BTU/hour	Typical: 1025 BTU/hour Maximum: 1100 BTU/hour
Weight:	14.5 lbs. (6.58 kg)	14.5 lbs. (6.58 kg)



VIPRION 2400 Chassis

Physical Specifications VIPRION 2400 Chassis

Dimensions	6.89" (17.5 cm) H x 17.64" (44.8 cm) W x 21.18" (53.8 cm) D rack-mount chassis 4 rack units
Weight:	42.5 lbs. (19.3 kg)
Power Supply:	AC power supply Two 100-127 VAC/200-240 VAC (1400W) auto ranging 17A per input line (max) DC power supply (option) Two 1400W 38 to 72 VDC 44A per input (max)
Operating Temperature:	32° to 104° F (0° to 40° C) per Telcordia GR-63-CORE 5.1.1 and 5.1.2
Relative Humidity:	5 to 85% at 104° F (40° C) per Telcordia GR-63-CORE 5.1.1 and 5.1.2
Safety Agency Approval:	EN 60950-1:2006, 2nd Edition Evaluated to all CB Countries UL 60950-1, 2nd Edition, CSA C22.2 No. 60950-1-03
Electromagnetic Emissions Certifications:	FCC Part 15 Class A VCCI Class A EN 300 386 V1.3.2 (2003-05) EN 55022:2006 + C1:2006 EN 61000-3-2:2000 EN 61000-3-3:1995 +A1:2000 EN 55022:2006 + C1:2006 Class A EN 61000-3-3:1995 +A1:2000+ A2:2005 EN 55024:1998 +A1: 2001 +A2:2003



VIPRION 2100 Blade

Physical Specifications VIPRION 2100 Blade

Traffic Throughput:	40 Gbps L4, 18 Gbps L7 10 Gbps Hardware Compression Maximum SSL TPS: 50,000 TPS Bulk crypto: 9 Gbps Included SSL TPS: 500/CPU Core 2000/Blade
Processor:	Single Quad Core (4 processors)
Memory:	16 GB
Hard Drive Capacity:	300 GB 10,000 RPM
Network Interfaces:	Gigabit Ethernet copper ports: 0 (Optional SFP) Gigabit fiber ports (SFP): 0 (Optional SFP) 10 gigabit fiber ports (SFP+) 8 SR (2 Included) Note: Only optics provided by F5 are supported.
Power Consumption:	Typical: 175W (conditions: 25C, 50% load, 110 VAC) Maximum: 265W (conditions: 40C, 110 VAC)
Heat Output:	Typical: 597 BTU/hour Maximum: 904 BTU/hour
Weight:	9.5 lbs. (4.3 kg)

Ordering Information

The VIPRION 4400 chassis includes these options:

- VIPRION 4400 blades—One blade is required.
 - VIPRION 4100 blade, or
 - VIPRION 4200 blade
- Performance Extreme Pack—Includes maximum SSL acceleration, maximum compression, advanced client authentication, and advanced routing
- BIG-IP® Application Security Manager™—web application firewall module

The VIPRION 2400 chassis includes these options:

- VIPRION 2400 blades—One blade is required.
 - VIPRION 2100 blade
- Performance Extreme Pack—Includes maximum SSL acceleration, maximum compression, advanced client authentication, and advanced routing
- BIG-IP Application Security Manager—web application firewall module

Professional Services and Support

F5 is dedicated to helping you get the most from your F5 products. To find out how F5 support services can help you improve your ROI, reduce administrative time and expense, and optimize the performance and reliability of your IT infrastructure, contact consulting@f5.com.

More Information

Visit these resources on f5.com to learn more about VIPRION.

Datasheets

[BIG-IP Local Traffic Manager](#)

[BIG-IP Application Security Manager](#)

White papers

[Clustered Multiprocessing: Changing the Rules of the Performance Game](#)

[VIPRION: The Cost of Management](#)

Podcast

[VIPRION: Unboxed](#)

F5 Networks, Inc. 401 Elliott Avenue West, Seattle, WA 98119 888-882-4447 www.f5.com

F5 Networks, Inc.
Corporate Headquarters
info@f5.com

F5 Networks
Asia-Pacific
apacinfo@f5.com

F5 Networks Ltd.
Europe/Middle-East/Africa
emeainfo@f5.com

F5 Networks
Japan K.K.
f5j-info@f5.com

